

SAILOR® 60 GX

Your Ka-band system for Inmarsat Global Xpress®

COBHAM

2014 Product Sheet

The most important thing we build is trust

The SAILOR 60 GX is a robust 3-axis marine stabilised antenna system designed specifically for the Inmarsat Global Xpress® satellite network. Using a Ka-band tuned radome for peak RF performance, it is a powerful enabler for the ever increasing bandwidth requirements in the maritime market and a perfect companion for the established SAILOR FleetBroadband terminals.

Dedicated development

The SAILOR 60 GX is a result of thousands of hours of research, development and rigorous testing that meets or exceeds the strict requirements set forth by Inmarsat. This ensures that with SAILOR 60 GX, the high speed maritime broadband provided by Global Xpress® is always available for business critical, operational and crew communication. With collaboration and IP applications becoming increasingly important to improving vessel and fleet efficiency, SAILOR 60 GX can be counted on to enable your ability to communicate and operate more efficiently.

Fast, flexible installation and integration

The SAILOR 60 GX is simple to install, setup, operate and commission, even by a non-specialist technician. The use of Ethernet over Coax (EOC) allows for four times the length over traditional coax only systems, so installation flexibility is high. It is easily integrated with SAILOR FleetBroadband to create a redundant, highly reliable network with the quality and coverage needed to perform in today's maritime environment. SAILOR 60 GX also uses the innovative Cobham IMA software platform, helping to make it ready to face the communications needs of the maritime market in the 21st century.

Remote functions for management and maintenance

The SAILOR 60 GX supports extensive remote monitoring and diagnostic capabilities. Managing multiple systems

across an entire fleet operating on identical networks is easy using the intuitive and secure user interface, which features extensive data logging capabilities. Secured Socket Layer (SSL) password protection provides high-levels of data security while extensive capabilities for online and off-line troubleshooting with the integration of a SAILOR FleetBroadband system enhance maintenance possibilities. Likewise, with full autonomous network and software upgrades you can be sure your system is operating with the latest software and features.

Testing and dual antenna installations

The SAILOR 60 GX is designed to meet some of the toughest shock and vibration specifications, including IEC EN 60945. It is also ready for seamless dual antenna installations for those ships that may experience excessive blockage zones.



SAILOR® 60 GX

Your Ka-band System for Inmarsat Global Xpress®



Typical Data for SAILOR 60 GX

SPECIFICATIONS	
Reflector Size	65 cm / 25.6 in
Radome	90 cm / 35.5 in D X 106 cm / 41.6 in H"
Tx Frequency	29.0-30.0 GHz
Rx Frequency	19.2-20.2 GHz
Tx Gain	44.0 dBi (typ)
Rx Gain	40.0 dBi (typ)
BUC	5 watt
Pedestal Type	3-axis:
Azimuth	Unlimited
Elevation Joint Angle	-15° to +115°
Weight	79 kgs / 175 lbs
Polarization	Circular
Stability Accuracy	0.1° RMS

Typical Data for Global Xpress Media Xchange Point (GMXP)

- Standard 19 inch 1U Rack Mount. (Slide Rails Optional)
- 43 x 43 x 4.35 cm / 17 x 17 x 1.75 in
- 110/220VAC, 47-63 Hz, Single Phase
- 3.0 kgs / 6.6 lbs
- 4 Ethernet Port Back (RJ)
- 1 Ethernet Port (Internal, RJ)
- 1 SMA Connector (Rx from RJ)
- 1 F-Connector (Diplexer to Modem RX Port)
- 4 Modem LEDs
- 2 GMXP Status LEDs
- 4 RS-232 pass through ports
- 1 NMEA 0183 serial port
- USB Device (Mini B)
- USB Host (Type A)
- SBS & Synchro Gyro Inputs

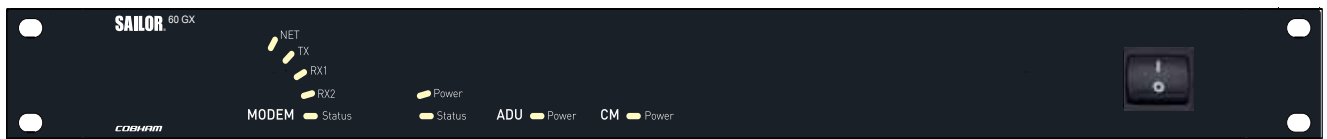

Three Mounting Configuration Options

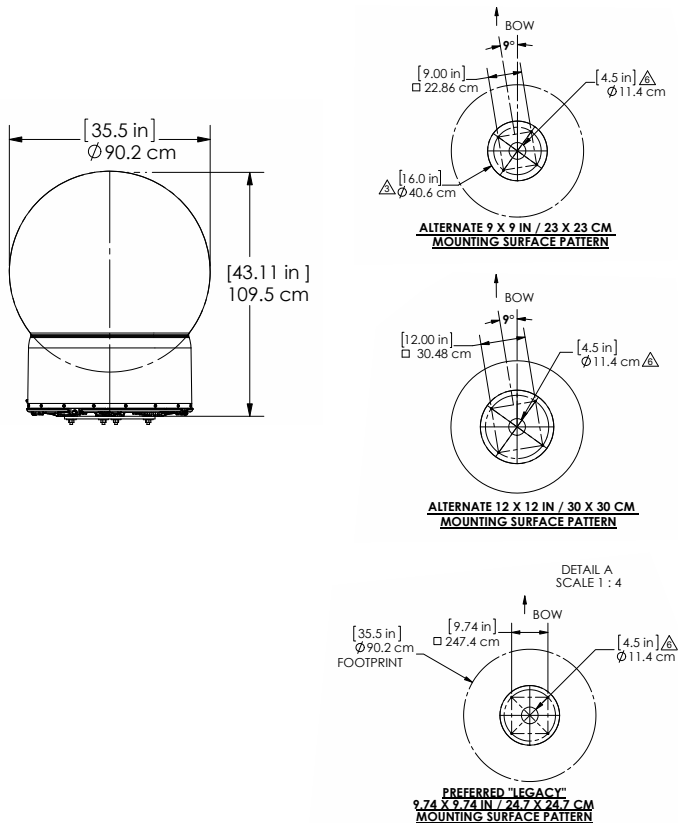

For further information please contact:

satcom.ohc@cobham.com